

BCS Chipper/Shredder

Models:
Bio 80 &
Bio 100

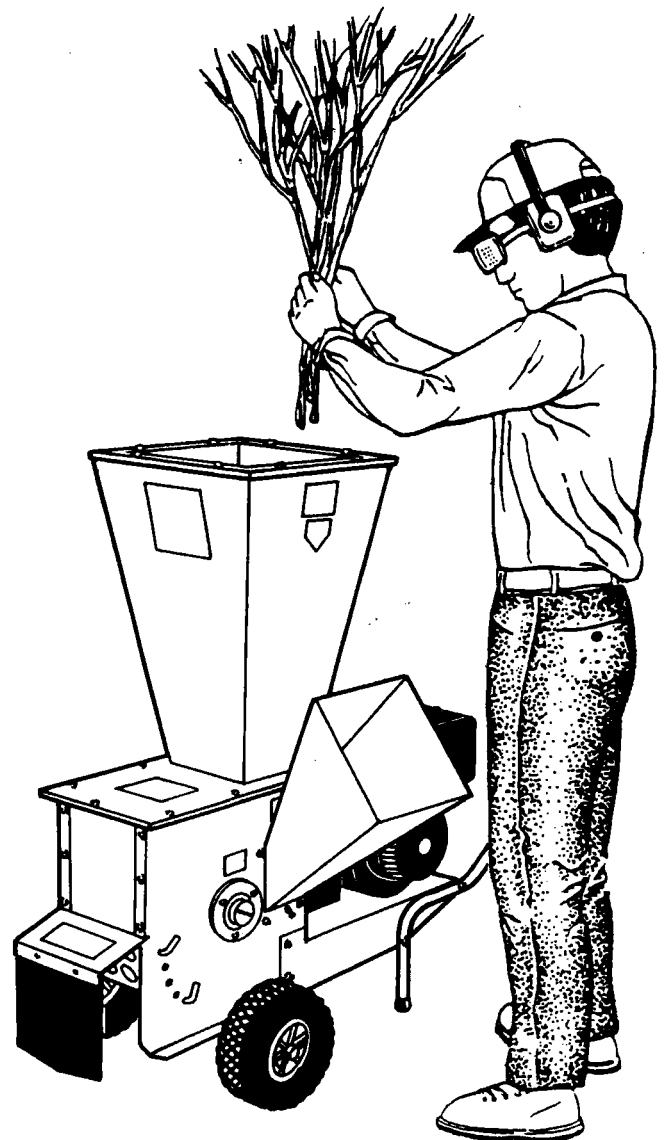

OWNERS MANUAL

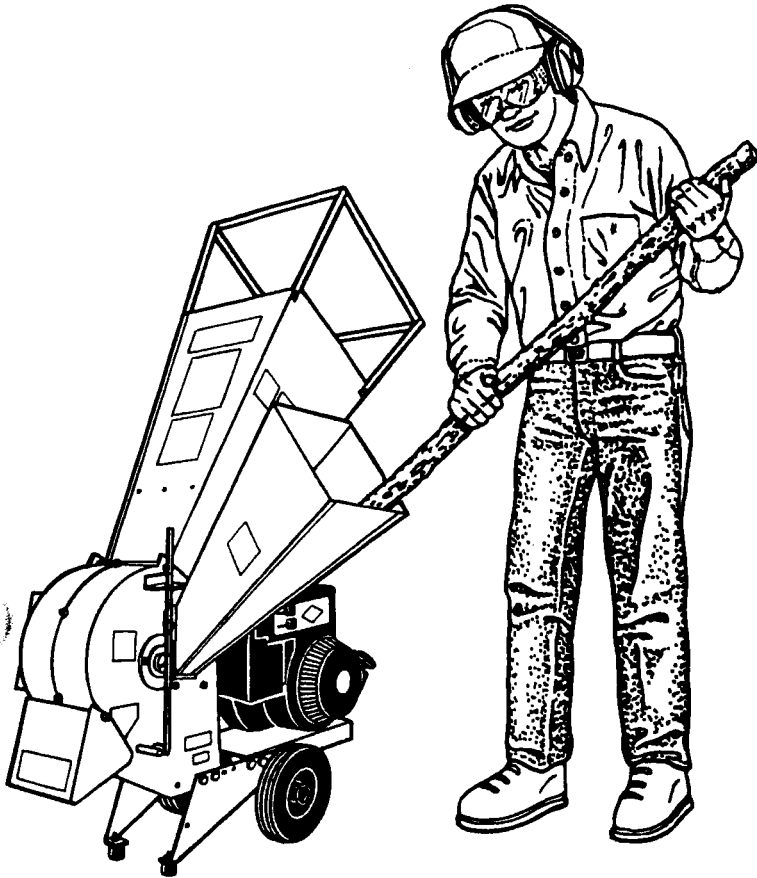

READ THIS OWNER'S MANUAL BEFORE ATTEMPTING TO
ASSEMBLE AND OPERATE THE CHIPPER/SHREDDER.

GENERAL PRECAUTIONS AND INSTRUCTIONS FOR USE OF CHIPPER/SHREDDER

TRAINING

READ THIS MANUAL PLUS THE ENGINE MANUAL BEFORE ASSEMBLING AND OPERATING THIS BCS CHIPPER/SHREDDER.

This unit is designed for operation by properly instructed adults only. Make sure that any person operating this equipment has read these manuals.

DO NOT LET CHILDREN OPERATE THE CHIPPER/SHREDDER.

KEEP THE OPERATING AREAS CLEAR OF PEOPLE AND ANIMALS. BE CAREFUL THAT CHILDREN DO NOT COME NEAR.

Do not operate this equipment in enclosed areas. Engine exhaust contains carbon monoxide. Carbon

monoxide is an odorless, deadly poisonous gas.

Do not allow hands to enter the Shredder hopper or the Chipper feed chute when the engine is running or the Chipper/Shredder shaft is rotating. When necessary to put hands and fingers into any opening of the unit, shut down engine, disconnect spark plug wire and wait until all movement stops. Check paint slash on the shaft of model Bio 100 Chipper/Shredder to be sure there is no movement.

When storing unit or leaving it unattended, make the engine unstartable by disconnecting the spark plug wire from the spark plug.

PREPARATION

The following body protection should be worn during operation of the Chipper/Shredder:

1. Wear snug-fitting clothing that protects body surfaces, and allows freedom of movement without being baggy. Never wear ties, scarfs or jewelry that could be caught in the machine.
2. Wear hearing protection.
3. Wear eye protection goggles stamped "Z87" (for ANSI Standard Z87.1).
4. When working in strong sunlight, protect your body with clothing and apply a sun block to exposed areas of skin. Wear sunglasses under the safety goggles.

Take the following precautions for the safe storage and handling of gasoline fuel:

1. Keep fuel supplies in approved type, properly labeled fuel containers.
2. Do not store fuels or fueled units in closed (unventilated) areas, or in garages or shops connected to human living quarters. Do not store fuel or fueled units where there are flames or sources of sparks such as electrical appliances and switches.

3. Obey all local regulations for the storage and handling of fuel.

4. Do not smoke when fueling, or fuel where fumes could be ignited by fire or sparks.

5. Do all fueling outdoors over non-flammable surfaces. If fuel is spilled on unit, wipe the unit dry and properly dispose of the wiping rag. ALWAYS MOVE THE UNIT AT LEAST 10 FEET (3 meters) from the fueling spot and fuel supplies before starting the engine.

6. Always remove the engine fuel cap very slowly to equalize tank pressure and avoid spurning of fuel. Keep your face and eyes away from the tank while loosening the cap.

7. Do not fuel a running or hot engine. Do not loosen the fuel cap until the engine has stopped. Then wait several minutes for the engine to cool before pouring fuel.

Operate the Chipper/Shredder only on a level surface. Do not operate the unit on paved or gravel surfaces.

Before starting, check that all screws, nuts, bolts and other fasteners are properly secured.

OPERATION

All chute safety covers and hand stops, deflectors and feed chutes must be in proper position. Do not operate if any safety devices or fastening parts are missing from the unit.

Before starting make sure that the grinding chamber contains no foreign objects that could interfere with operation or eject from the intake openings at high speed.

Operate only when there is good visibility. Do not operate at dusk or at night.

Do not let hands or any other part of your body, or your clothing, enter either of the Chipper/Shredder intake openings, or go near the discharge opening unless the engine spark plug wire is disconnected and Chipper/Shredder shaft is not rotating.

The zone of operation is anywhere except on the discharge side or in front of the Chipper chute. Do not stand directly in front of the Chipper feed chute. Do not peer down into the Shredder hopper. Materials can be thrown back out of the intakes. Do not go on the discharge side of the unit during operation.

Allow engine to warm up. Then operate at maximum

throttle speed setting. Never change the engine governor setting or overspeed the engine to gain power.

Side branches should be lopped off to avoid clogging the hopper or chute.

DISCONNECT THE SPARK PLUG WIRE FROM THE SPARK PLUG TO ENSURE AGAINST ACCIDENTAL STARTING DURING ANY OF THE FOLLOWING OPERATIONS:

1. Repairs or adjustments to unit or engine.
2. Before transport or storage, or whenever you are going to leave the unit unattended.
3. Before removing a foreign object from the unit, or before starting cleaning, inspection or maintenance work.
4. If the machine starts to vibrate or suddenly run erratically. A poorly running unit should be inspected by an authorized BCS servicing dealer before further use.

Do not touch the engine when it is running or when surfaces are still hot from operation.

MAINTENANCE AND STORAGE

Clean leaves, debris and fuel off the unit to avoid the possibility of fire.

Keep the unit in good working condition. Clean the unit at regular intervals, and check each time for loose or missing parts.

Do all items of maintenance explained in this Chipper/Shredder Owners Manual. Do not attempt disassembly or repairs not included in instructions from BCS or the engine manufacturer. Some adjustments and internal servicing of both engine and the BCS Chipper/Shredder should be done by BCS trained service personnel at an authorized BCS servicing dealer or distributor.

Shut down the engine immediately if a foreign object gets into the grinding chamber, or the unit suddenly makes loud noises or vibrates excessively.

When the Chipper/Shredder is stopped for servicing, inspection, storage or to change an accessory, make sure the spark plug wire is disconnected from the spark plug. Allow the machine to cool before making any inspections, adjustments, etc.

Allow the unit to cool before putting it away. Keep it out of the reach of children, and where sparks cannot ignite the gasoline fumes.

Do not store the unit with fuel in the system. Disconnect the fuel line at the carburetor inlet and drain the fuel into a fuel container. Then reconnect the fuel line. Start and run the engine until it stops from lack of fuel. Dispose of the drained gasoline safely.

Store the cleaned and drained Chipper/Shredder in a well-ventilated place, protected from dampness and the weather.

UNPACKING THE Bio 80

1. Open the top of the carton, and lift out the first piece you see. This is the hand shield that goes onto the Shredder hopper at the top of the unit.
2. Remove the bubble packing and lift out the large Shredder hopper. Remove the Chipper discharge deflector that is inside the hopper.
3. Reach into the carton and pull out the bag containing instructions and some small parts.
4. Slit the corners of the carton on the engine side (the side away from the belt cover). Lay the side of the carton down flat. Remove the two wheels, then slide the unit free of the carton.

IMPORTANT

EXAMINE ALL PARTS OF THE UNIT FOR SHIPPING DAMAGE. IF THERE IS DAMAGE, NOTIFY THE SHIPPER.

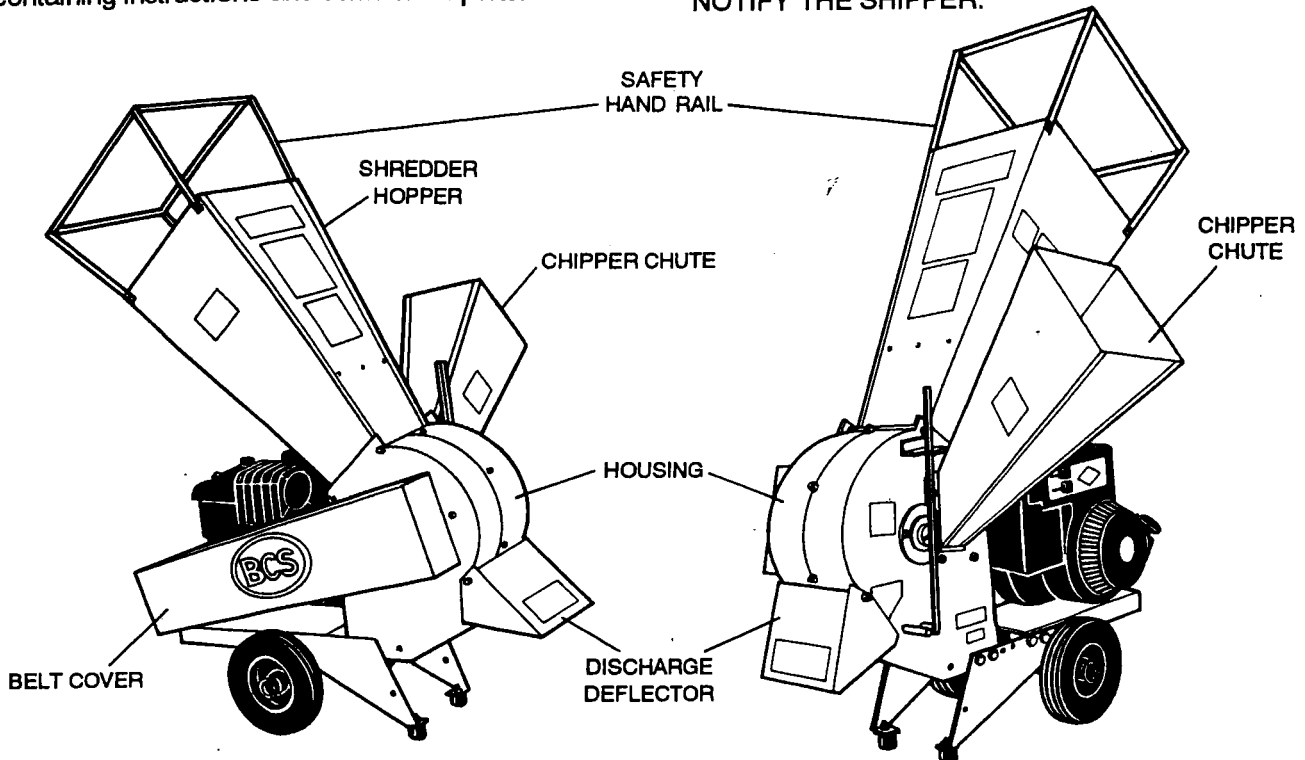

ASSEMBLING THE Bio 80

1. Mount the two wheels on the axles. Insert the pins (from bag) and turn down their circlips over the wheel hubs.
2. With a #17 metric wrench, remove hex lock nuts and flat washers from upper mounting bolts on the Chipper/Shredder housing. Pull out the long bolts.
3. Position the Shredder hopper onto the housing. The side with the model name and instruction decals goes toward the curved end of the unit housing.
4. Shove the long bolts back through the housing and the hopper. Secure with the flat washers and nuts that were removed in step 2.
5. With a #10 wrench, install the safety hand rail to the top of the hopper with four M8 x 16mm bolts and hex lock nuts.
6. With a #13 wrench, remove the two hex lock nuts and flat washers from the mounting studs, and mount the Chipper intake chute to the housing with these fasteners.
7. The position of the discharge deflector on the Chipper/Shredder housing must be adjusted before first use. Loosen the hex lock nuts on each side with a #13 wrench. Raise and lock the deflector in a position where discharge can occur only below the deflector.
8. With a #13 wrench, use flat washers and hex-locknuts to secure the two rubber feet to the frame.

NOTE

Position of deflector may be adjusted to direct the discharge as desired. But do not adjust so low that unit discharges above the deflector.

UNPACKING THE Bio 100

1. Cut the strapping and lift the top and sides of the box off the wooden skid base.
2. Remove the wheels.
3. Remove and strip the Shredder hopper of its packing material. Take two handlebars, a bag of parts, an instructions package and the wheel axle from the hopper.
4. Remove the package containing three rods and hairpins and five tubes. These parts are for optional

use. They replace the curved discharge screen now on the unit.

5. Free the unit from the wooden skids by pulling out the two nails.

IMPORTANT

BEFORE ASSEMBLING THE UNIT, CHECK THE CONTENTS. NOTIFY THE SHIPPER OR DEALER IF THERE ARE ANY MISSING OR DAMAGED PARTS.

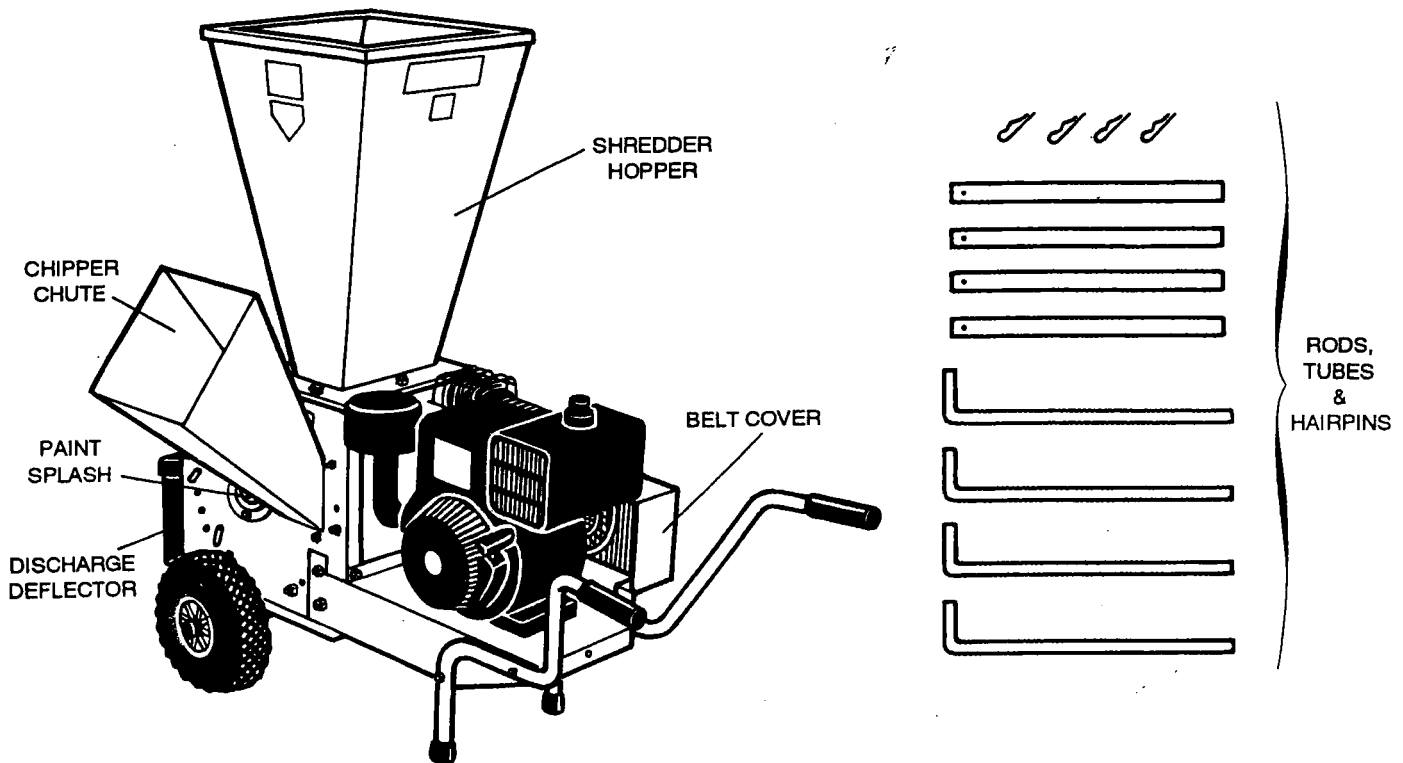

ASSEMBLING THE Bio 100

1. Block up front of unit off the wooden skids. Slide the axle under the base and hold in position with the studs of axle protruding through the four holes in the base. Start a flat washer and M8 hex-lock nut onto each stud. Tighten all four nuts with a #13 wrench.
2. Slide the wheels partway onto the axles. Then remove the blocking. Pick up the engine end and walk the unit clear of the skid base. Using large hairpins (from parts bag) on both sides of each wheel, pin the wheels in position.
3. Block up the engine end for attachment of the

handle bars at threaded holes on each side of the base. With a #13 wrench, install M8 flat washers and hex-lock nuts at the four holes. Tap the rubber grips onto the handlebar ends.

4. Mount the Shredder hopper onto the unit. Slip a flat washer onto each of eight M8 x 20mm bolts. Drop the bolts through the eight holes in the hopper. Secure with a flat washer and M8 hex-lock nut on each bolt.
5. Mount the Chipper chute on the three studs surrounding the intake, on side of unit, and secure with flat washers and M8 hex-lock nuts.

CHIPPER/SHREDDER OPERATION

SETTING UP FOR OPERATION

⚠ DANGER

Material can be thrown out from both feed and discharge openings.

1. Wear safety goggles and a hat.
2. Do not look into shredder hopper or place your head over it when the unit is running.
3. Do not go on the discharge side of the unit or directly in front of the Chipper chute.

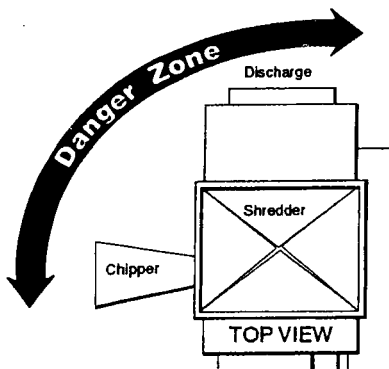

1. The unit rests on rubber tires and bumpers, but should be further cushioned by setting it only on firm, level ground. Do not place it on paved or gravel surfaces. The unit may be placed on a blanket or tarp to catch the processed material.

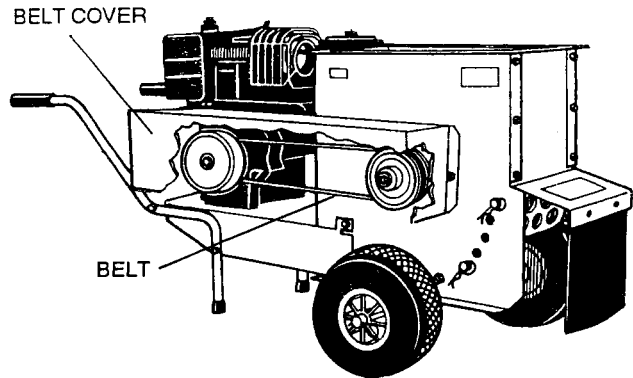

2. Inspect the hopper before starting the engine. On the model Bio 80, pull the starter rope very slowly to see if the engine and Chipper/Shredder turn over freely. On the model Bio 100, reach under the belt cover, grasp and pull belt to the left and right to see if the Chipper/Shredder shaft is free to turn.

⚠ WARNING

Inspect what you plan to feed into the hopper. Remove glass, metal, brick, stones, long or thick branches, or anything else that could damage the machine or fly out at high speed.

3. ALWAYS OPERATE THE CHIPPER/SHREDDER AT FULL THROTTLE.
4. Chipping and shredding may be done simultaneously.

CHIPPING WOOD

⚠ DANGER

DO NOT PUT HANDS DOWN INTO THE CHUTE WHEN THE UNIT IS RUNNING.

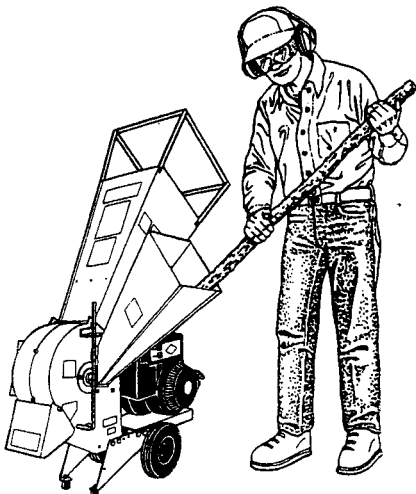

1. Wood in diameters up to 2-1/2" for the Bio 80 and 3-3/4" for the Bio 100 can be fed through the Chipper chute.
2. Put the thickest end of the branch into the chute. Side branches must be either bent to fit or lopped off. Find just the right feed pressure to apply not too much! Do not let the chipper overfeed itself. Pull back when engine bogs down and wait for speed to resume before feeding wood. On the Bio 100 unit, the engine must maintain high speed under load to keep the centrifugal clutch solidly engaged. Proper feed pressure and engine speed are important for the life of both models.

⚠ WARNING

Do not go on the discharge side of the unit or stand directly in front of the intake chute when feeding the Chipper. Keep to one side of the chute.

3. NEITHER PULL OUT NOR PUSH IN the short end pieces with your hands. Use the next log or branch to feed the short end through the Chipper each

time. Short ends sometimes feed themselves through the chipper, but very often are thrown out.

SHREDDING

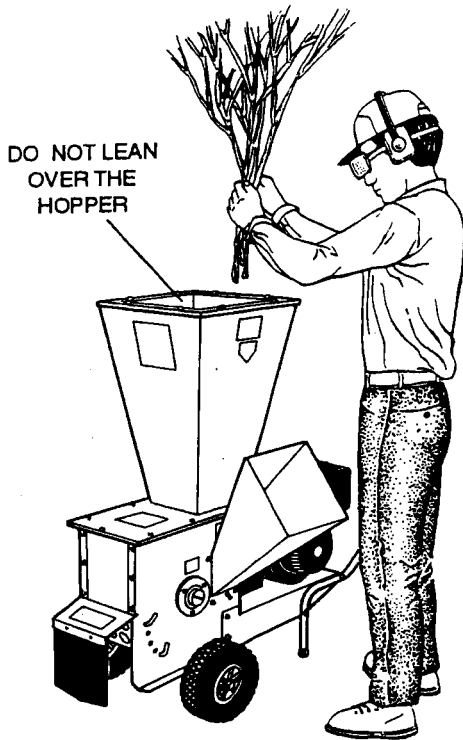

thick weeds or branches into the hopper with force overfeeds the flails (knife blades) and jams the Shredder. Rods and tubes can replace the curved "swiss cheese" screen on model Bio 100 for improved shredding of wet materials or finer chips (see "Changing Screen on Bio 100").

WARNING

Always shut down the engine and wait until all movement stops before clearing the hopper or discharge screen, and before removing the hopper to remove a blockage.

4. To clear Bio 80 discharge: Shut down the unit and disconnect the spark plug wire. Free up and move the screen latch lever forward to open the discharge screen. Clear out material with wooden tool handle or brush. Do not reach inside with fingers because the flails (knife blades) are very sharp. Pull the starter rope to feel whether the shafts turn freely. If so, latch screen with the lever and connect the wire to the spark plug.

DANGER
Shredder grasps and pulls material down into hopper with surprising speed. Do not wear rings, bracelets, jewelry, watches or any other items that could be caught in the material and draw your hands into the Shredder. Hold the material very lightly. Do not use a hard throwing or spearing force. Gloves, when worn for shredding, should be large enough to slip off your hands if caught in the material.

1. Be very careful what you put into the hopper. The Shredder cannot handle cloth, string, plastics, glass, rubber, rocks or paving, brick, large wood chunks, metal, thick branches and long vines. Any material more than two centimeters (about 3/4") thick can jam the Shredder.
2. Soggy soil, green garden wastes and wet grass clippings may require mixing in with some dry wood chips or leaves to avoid clogging the Shredder.
3. Preparation of the material may help in feeding it through the hopper. Cutting side branches off stems, for example, helps the mass of material slide down the hopper walls. Adding too much material at a time can clog the works. Throwing

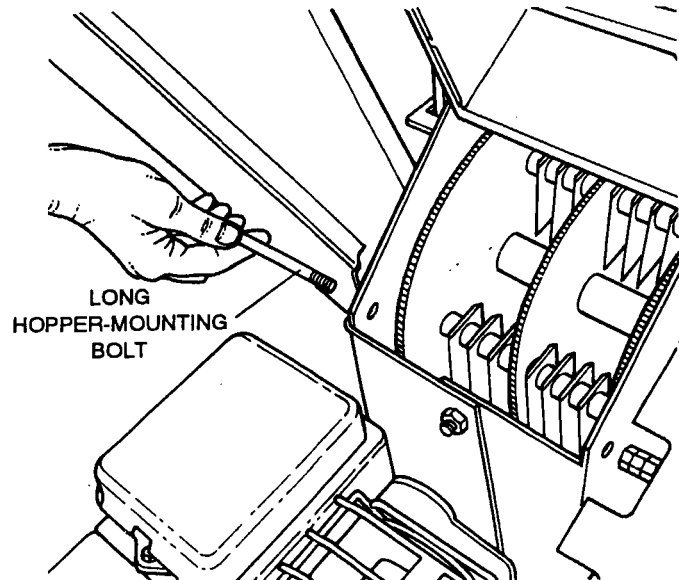

5. To clear Bio 80 blockage: Shut down the unit and disconnect the spark plug wire. Remove the nut and flat washer stud on the right side of the Chipper chute. Loosen the other stud nut. Remove the lock nut and flat washer from the long hopper-mounting bolt nearest the engine. Pivot the hopper forward for access to the grinding chamber. Release lever

CHANGING SCREEN ON Bio 100

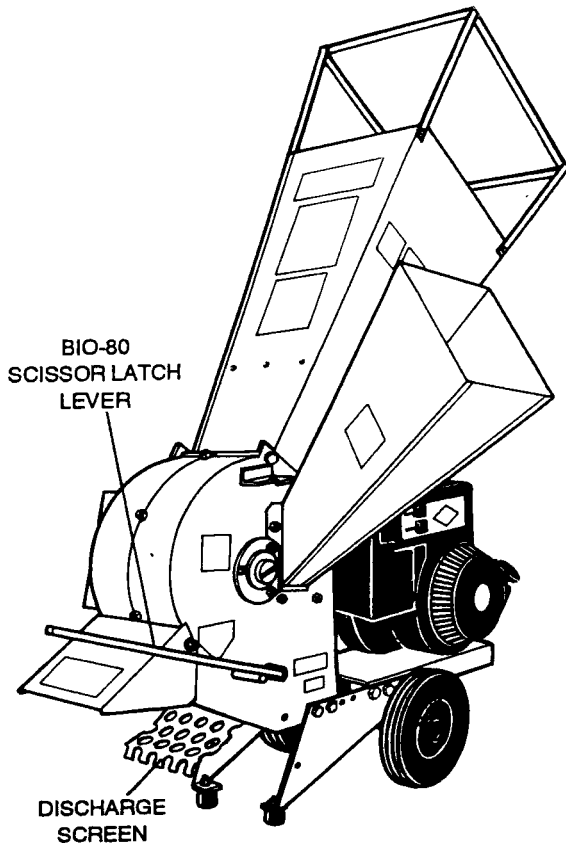

to open the discharge screen (see previous paragraph). Wear heavy work gloves while clearing the blockage. Check that the engine and Chipper shafts turn freely before you reassemble hopper and chute to the unit and connect the spark plug wire.

IMPORTANT

ANY TIME THE CHIPPER/SHREDDER AND ENGINE SEEM TO BOG DOWN, SHUT DOWN THE UNIT, AND CLEAR THE GRINDING CHAMBER, PER ABOVE INSTRUCTIONS. OR SEE "TROUBLESHOOTING" ON PAGE 9 FOR POSSIBLE CAUSES AND REMEDIES.

6. To clear Bio 100 discharge screen or internal blockage: These processes require temporary removal of the belt cover and the discharge screen. Removal of the hopper may be required to remove internal blockage. Removal of objects between the Chipper hopper and the rotating members, requires removing the hopper assembly, held by eight sets of M8 x 20 bolts, lock washers and hex nuts.

WARNING

On the centrifugal clutch-equipped Bio 100 the Chipper/Shredder shaft may continue to rotate silently after engine shut-down. After shutting down engine, check the paint slash on the end of the Chipper/Shredder shaft. Be sure the shaft has stopped rotating before you work on the unit.

WARNING

The engine-grounding lever over the spark plug boot on the Bio 100 has a sharp point to penetrate the boot and ground the ignition. Be careful of this point when disconnecting the spark plug wire.

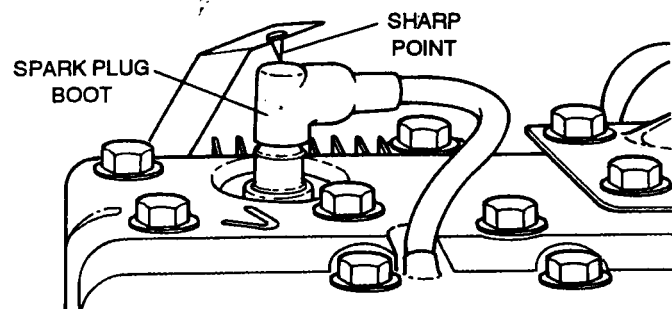

IMPORTANT

THIS DISASSEMBLY ROUTINE SHOULD BE FOLLOWED TO REMOVE THE SCREEN EITHER FOR CLEARING OUT DEBRIS OR REPLACEMENT WITH RODS AND TUBES.

1. Shut off engine, disconnect spark plug wire and wait for unit rotation to stop before doing this work.
2. Remove the belt cover, held in two places by M8 bolts, flat washers and hex nuts.

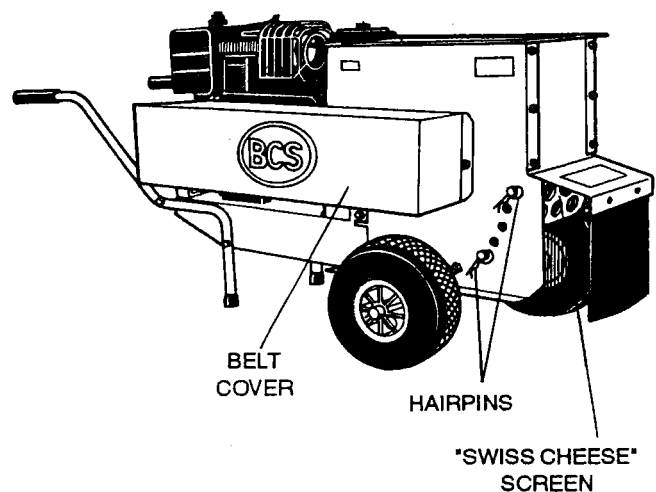

- Look at the series of six holes on the chute side of the unit. Two of these holes have long rods running through the curved discharge screen to the back of the unit. Remove the hairpins and slide out the rods. The curved screen will be replaced by five sets of rods and tubes in the next step.
- The bottom hole of the series of six will not be used. Start one rod into the top position hole. Slip a tube onto the rod and push the rod through the hole on the rear side (see figure at right). Lock in place with a hairpin. Install the four other rods and tubes in the same manner, leaving the bottom hole empty.

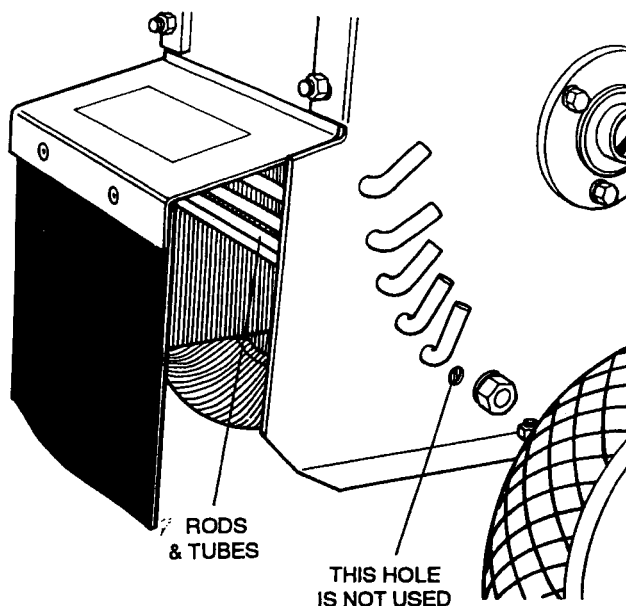

⚠ DANGER

Do not use this Chipper/Shredder with the discharge left unscreened. Discharge must be covered either with the rods and tubes or the standard screen.

MAINTENANCE, ADJUSTMENT AND TROUBLESHOOTING

⚠ WARNING

Shut off engine. Wait for the unit to stop. Then remove the spark plug wire from the spark plug before working on the unit. Do not bring fuel or a fueled engine near flame or sparks.

- Wipe exterior of the unit clean after each use. Check for loose or missing parts.
- Clean out the hopper and the discharge screen before next use.
- Do not remove the spark plug unless there is trouble starting the engine. Try starting with a new, properly gapped plug.
- If a new spark plug does no good, drain fuel tank and safely dispose of fuel that may not be fresh. Fill tank with fresh gasoline and try starting engine.
- If a new spark plug and fresh gasoline does not start the engine, consult the operator's manual supplied by the engine manufacturer. Various detailed service publications for your engine are available from the engine manufacturer.
- If Chipper/Shredder output (volume) drops off while engine runs at working speed, check tension of the drive belt. Belt should be taught enough not to slip, but not so tight as to fray. To increase belt tension: loosen the four engine mounting bolts; pull engine back on the mount to increase tension and tighten the bolts.
- On the Bio 100 only: If tightening the belt tension does not restore proper Chipper/Shredder volume, the centrifugal clutch may be worn and slipping. Have this checked by your BCS servicing dealer or authorized distributor can disassemble the unit and sharpen or replace the knives.
- Do not keep fuel in the unit for a longer than one month. Before storing the unit, disconnect the fuel line at the carburetor inlet and drain the fuel into an approved fuel container. Reconnect the fuel line start and run engine until it stops from lack of fuel. Dispose of the gasoline safely. Store unit in a well-ventilated place, protected from dampness and the weather.

